

500kHz 5A High Efficiency Synchronous PWM Boost Converter



General Description

The FP6276A is a current mode boost DC-DC converter with PWM/PSM control. Its PWM circuitry with built-in includes a high side 70mΩ P-channel MOSFET switch and low side 70mΩ N-channel MOSFET make this regulator highly power efficient. The internal compensation network also minimizes as much as 6 external component counts. The non-inverting input of error amplifier connects to a 0.6V precision reference voltage and internal soft-start function can reduce the inrush current.

Features

- Current mode with PWM/PSM control
- Input Voltage range: 2.4V~4.5V
- Shutdown current: <1uA
- Oscillator frequency: 500KHz
- Reference voltage: 0.6V +/-2%
- Load disconnect during shutdown
- Cycle-by-cycle current limit at Low side switch
- Start up pre-charge by linear charge current 2A
- Low $R_{DS(on)}$: Low side 70mΩ, High side 70mΩ.
- Protection: OTP, Output OVP, OCP, SCP
- Internal Compensation
- Internal Soft-start: 7ms
- Package: SOP8(EP)

Applications

- Chargers
- Handheld Devices
- Portable Products
- Power Bank

Typical Application Circuit

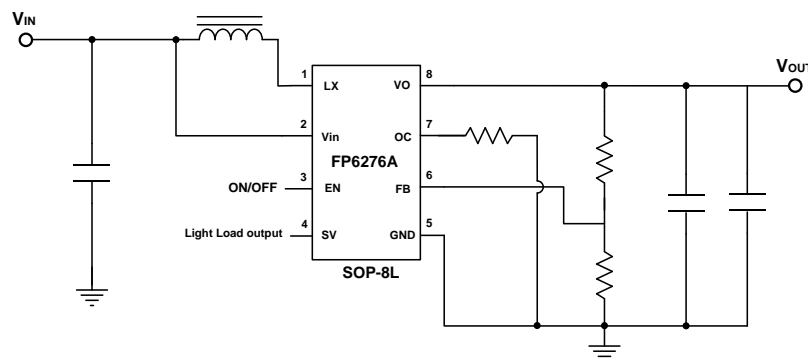

This datasheet contains new product information. Feeling Technology reserves the rights to modify the product specification without notice. No liability is assumed as a result of the use of this product. No rights under any patent accompany the sales of the product.

Function Block Diagram

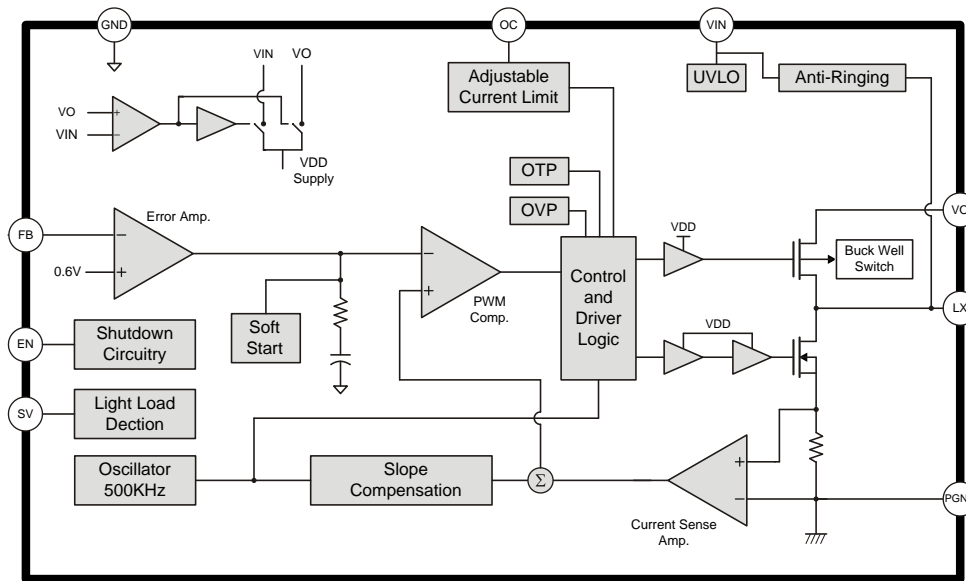

Pin Descriptions

SOP-8L (EP)

Top View

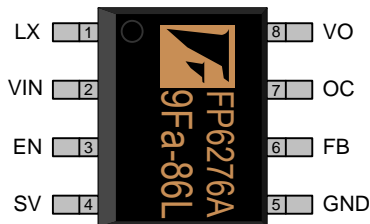

Bottom View

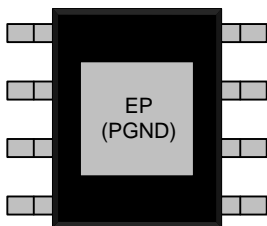

Name	No.	I / O	Description
LX	1	I	Power Switch Output
VIN	2	P	IC Power Supply
EN	3	I	Enable Control (Active High)
SV	4	O	Light Load Detection Signal
GND	5	P	IC Ground
FB	6	I	Error Amplifier Inverting Input
OC	7	I	Output Current Limit Detect
VO	8	O	Output Voltage Pin
EP	9	P	IC Power Ground

This datasheet contains new product information. Feeling Technology reserves the rights to modify the product specification without notice. No liability is assumed as a result of the use of this product. No rights under any patent accompany the sales of the product.

Marking Information

SOP-8L(EP)

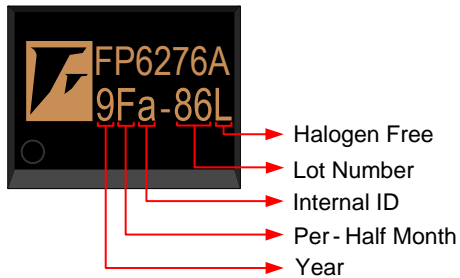

Halogen Free: Halogen free product indicator.

Lot Number: Wafer lot number's last two digits.

For Example: 132386TB → 86

Internal ID: Internal Identification Code.

Per-Half Month: Production period indicated in half month time unit.

For Example: January → A(Front Half Month), B(Last Half Month)

February → C(Front Half Month), D(Last Half Month)

Year: Production year's last digit

Ordering Information

Part Number	Operating Temperature	Package	MOQ	Description
FP6276XR-G1	-40°C ~ 85°C	SOP-8L(EP)	2500EA	Tape & Reel

Absolute Maximum Ratings

Parameter	Symbol	Conditions	Min.	Typ.	Max.	Unit
Supply Voltage	V_{IN}		0		6	V
LX Voltage	V_{LX}		0		6	V
EN,FB Voltage			0		6	V
Thermal Resistance (Note1)	θ_{JA}	SOP-8L(EP)			+83	°C / W
Junction Temperature	T_J				+150	°C
Operating Temperature	T_{OP}		-40		+85	°C
Storage Temperature	T_{ST}		-65		+150	°C
Lead Temperature		(soldering, 10 sec)			+260	°C

Note1:

θ_{JA} is measured in the natural convection at $T_A=25^\circ\text{C}$ on a low effective thermal conductivity test board of JEDEC 51-3 thermal measurement standard.

IR Re-flow Soldering Curve

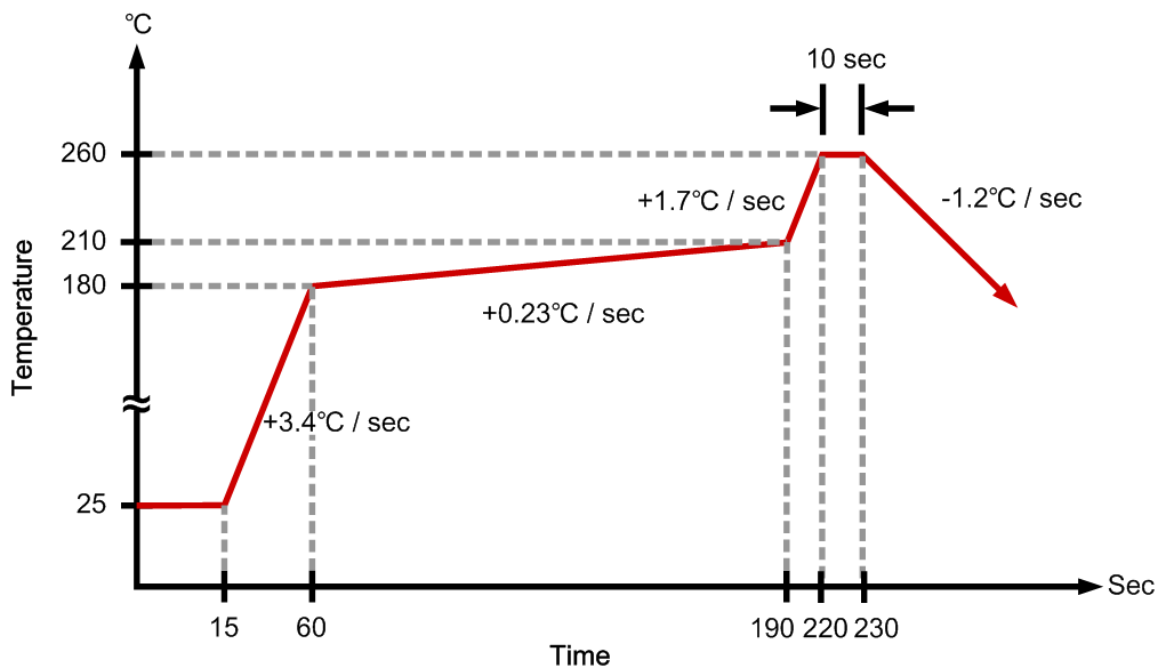

Recommended Operating Conditions

Parameter	Symbol	Conditions	Min.	Typ.	Max.	Unit
Supply Voltage	V_{IN}		2.6		4.5	V
Operating Temperature Range	T_A	Ambient Temperature	-40		+85	°C

DC Electrical Characteristics ($V_{IN}=3.3V$, $T_A=25^{\circ}C$, unless otherwise specified)

Parameter	Symbol	Conditions	Min.	Typ.	Max.	Unit
Input Voltage	V_{IN}		2.4		4.5	V
Under Voltage Lockout	V_{UVLO}			2.1		V
UVLO Hysteresis				0.1		V
Quiescent Current	I_{CC}	FB=1.0V, No switch		280		μA
Shutdown Current	I_{CC}	$V_{EN}=GND$		0.1		μA
Operation Frequency	f_{OSC}	$V_{FB}=0.6V$		500		kHz
Maximum Duty Ratio	%			90		%
Feedback Voltage	V_{REF}	$V_{IN}=5V$	0.588	0.6	0.612	V
Enable Voltage	V_{EN}		0.96			V
Shutdown Voltage	V_{EN}				0.6	V
Soft-Start Time	t_{SS}	$V_{IN}=5V$		7		ms
High Side PMOS RDS(ON)	$I_{LX(PMOS)}$			70		mΩ
Low Side NMOS RDS(ON)	$I_{LX(NMOS)}$			70		mΩ
Switch Current Limit	I_{OCP}			6		A
OVP Threshold Voltage on OUT Pin	V_{OVP}			6		V
Thermal Shutdown Threshold	T_{OTP}			150		°C
Thermal Shutdown Hysteresis				30		°C

This datasheet contains new product information. Feeling Technology reserves the rights to modify the product specification without notice. No liability is assumed as a result of the use of this product. No rights under any patent accompany the sales of the product.

Function Description

Operation

The FP6276A is a synchronous boost converter. The constant switching frequency is 500 kHz and operates with pulse width modulation (PWM). The FP6276A is highly efficient, with internal and synchronous switches. In shutdown mode reduces quiescent current to less than 0.1μA.

Soft Start Function

Soft start circuitry is integrated into FP6276A to avoid inrush current during power on. After the IC is enabled, the output of error amplifier is clamped by the internal soft-start function, which causes PWM pulse width increasing slowly and thus reducing input surge current.

Current Limit Program

A resistor between OC and GND pin programs peak switch current. The resistor value should be between 37.5k and 300k. The current limit will be set from 5 A to 0.8A. Keep traces at this pin as short as possible. Do not put capacitance at this pin. To set the over current trip point according to the following equation:

$$I_{OCP} = \frac{180000}{R3} + 0.2$$

Over Temperature Protection (OTP)

FP6276A will turn off the power MOSFET automatically when the internal junction temperature is over 150°C. The power MOSFET wake up when the junction temperature drops 30°C under the OTP threshold temperature.

Over Voltage Protection (OVP)

In some condition, the resistive divider may be unconnected, which will cause PWM signal to operate with maximum duty cycle and output voltage is boosted higher and higher. The power MOSFET will be turned off immediately, when the output voltage exceeds the OVP threshold level. The FP6276A VO Pin OVP threshold is 6V.

Application Information

Inductor Selection

Inductance value is decided based on different condition. 3.3uH to 4.7uH inductor value is recommended for general application circuit. There are three important inductor specifications, DC resistance, saturation current and core loss. Low DC resistance has better power efficiency. Also, it avoid inductor saturation which will cause circuit system unstable and lower core loss at 1 MHz.

Capacitor Selection

The output capacitor is required to maintain the DC voltage. Low ESR capacitors are preferred to reduce the output voltage ripple. Ceramic capacitor of X5R and X7R are recommended, which have low equivalent series resistance (ESR) and wider operation temperature range.

Output Voltage Programming

The output voltage is set by a resistive voltage divider from the output voltage to FB. The output voltage is:

$$V_{OUT} = 0.6V \left(1 + \frac{R1}{R2} \right)$$

Layout Considerations

1. The power traces, consisting of the GND trace, the LX trace and the V_{IN} trace should be kept short, direct and wide.
3. Place C_{IN} near V_{IN} pin as closely as possible to maintain input voltage steady and filter out the pulsing input current.
4. The resistive divider R1 and R2 must be connected to FB pin directly as closely as possible.
5. FB is a sensitive node. Please keep it away from switching node, LX.
6. The GND of the IC, C_{IN} and C_{OUT} should be connected close together directly to a ground plane.

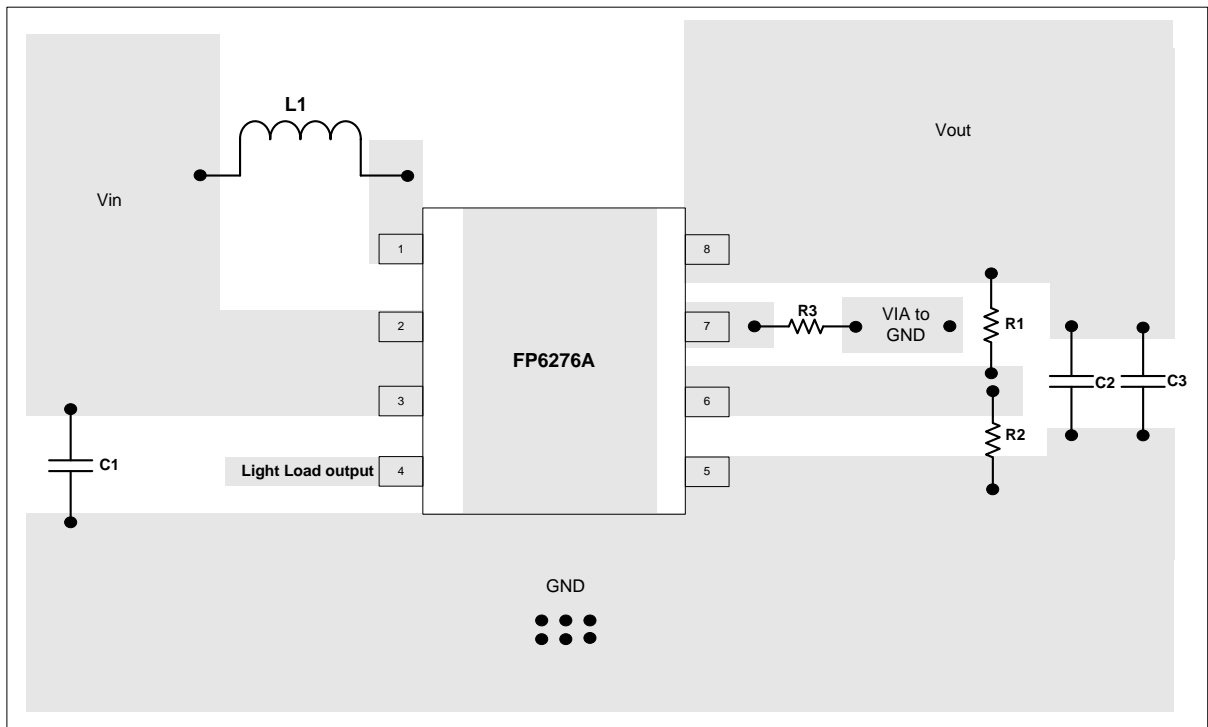

Suggested Layout

Typical Application

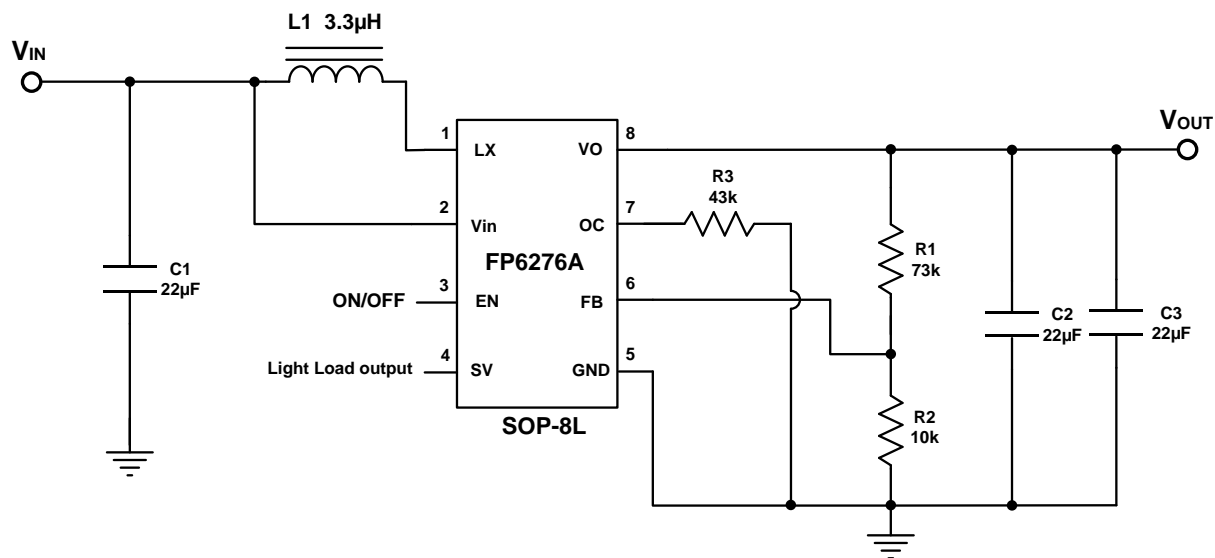

This datasheet contains new product information. Feeling Technology reserves the rights to modify the product specification without notice. No liability is assumed as a result of the use of this product. No rights under any patent accompany the sales of the product.

Package Outline

SOP-8L (EP)

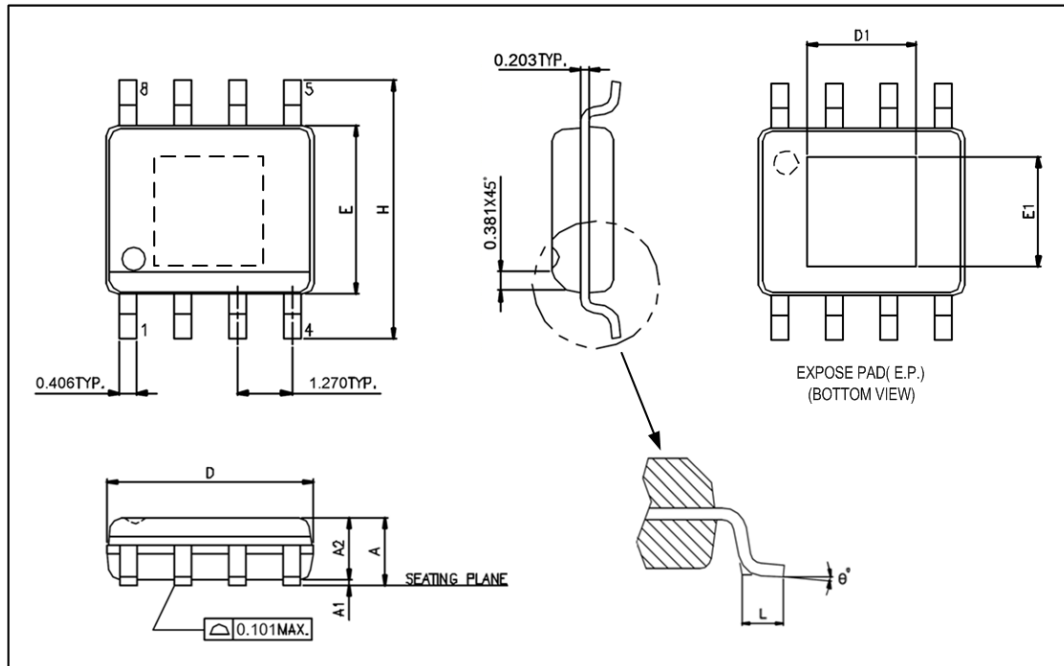
Unit: mm

Symbols	Min. (mm)	Max. (mm)
A	1.346	1.752
A1	0.050	0.152
A2		1.498
D	4.800	4.978
E	3.810	3.987
H	5.791	6.197
L	0.406	1.270
θ°	0°	8°

Exposed PAD Dimensions:

Symbols	Min. (mm)	Max. (mm)
E1		2.184 REF
D1		2.971 REF

Note:

1. Package dimensions are in compliance with JEDEC outline: MS-012 AA.
2. Dimension "D" does not include molding flash, protrusions or gate burrs.
3. Dimension "E" does not include inter-lead flash or protrusions.

This datasheet contains new product information. Feeling Technology reserves the rights to modify the product specification without notice. No liability is assumed as a result of the use of this product. No rights under any patent accompany the sales of the product.